

Agreement with Customers Having Private Solar Generation

Marshalls Energy Company



Agreement with Customers Having Private Solar Generation

Customer:

Address:

Account Number:

Customer Solar Generation Systems Policy

The above-named Customer is connected to the MEC distribution network and has been identified as having solar facilities on the premises. As a result, Customer is subject to the "Private Solar Generation Systems Policy and Regulation by Network Connected MEC Customers" (MEC Solar Policy), a copy of which is included in this Agreement. The Policy specifies the conditions that must be met by customers with solar facilities.

Customer Obligations with Respect to Solar Facilities

Customer accepts the terms of the MEC Solar Policy which include, but are not limited to:

- Compliance with the technical specification and connection configuration requirements.
- Accuracy of the information contained in the "Customer Solar Facility Form," which is attached to and made a part of this Agreement.
- Customer obligation to notify MEC if there are any changes to the solar facilities or to the connection configuration.
- Obligation to pay the Backup Capacity Charge in accordance with the terms specified in the invoice provided by MEC.
- In the event Customer does not pay the invoice according to terms, Customer is subject to disconnection from the MEC network.
- If the electrical configuration of the Customer connection changes and is no longer in compliance with the requirements, Customer will be required to immediately conform to the requirements or be subject to disconnection from the MEC network.
- The current Backup Capacity Charge is \$0.02 per installed watt of solar capacity per month. That value may change as the MEC fixed costs related to generation and distribution facilities change.

Agreed to by Customer:

Signature: _____

Name: _____ Date: _____

Attachments:

1. Private Solar Generation Systems Policy and Regulation by Network Connected MEC Customers
2. Customer Solar Facility Form

Agreement with Customers Having Private Solar Generation

Private Solar Generation Systems Policy and Regulation by Network Connected MEC Customers

1. Purpose

This policy and regulation are issued to inform stakeholders of the manner in which MEC will deal with the issue of customers or other entities that have or plan to install solar panels at their homes/facilities.

2. Background

The current MEC Majuro distribution network is based on a radial design with outdated technology, making it highly susceptible to fluctuations and disturbances. Directly connecting various individual solar systems to this network without centralized management can lead to power instabilities, overloading, and potential damage to both the grid and end-user equipment.

The integration of variable renewable energy sources like solar panels requires sophisticated control mechanisms to manage power fluctuations and maintain grid stability. Systems not owned or operated by MEC may lack the necessary controls, posing risks to the safety and reliability of the Majuro grid infrastructure.

High penetration of renewables can lead to an overall reduction in short-circuit currents, potentially causing protection systems to malfunction. During periods of low demand, excess generation from distributed solar can cause reverse current flow, leading to operational challenges.

Additional technical information on renewable energy integration and strengthening of the distribution network is available in the “Integrated Resource and Resiliency Plan” (IRRP) for Marshall’s Energy Company” as part of the Asian Development Bank Supplemental Management Operations Initiative.

3. Connection of Solar Generation to the MEC Network

POLICY #1
NO SOLAR GENERATION, OTHER THAN THAT OPERATED OR CONTRACTED BY MEC, CAN EVACUATE POWER TO THE MAJURO GRID

4. Customers of MEC Utilizing on-site Solar Generation

As said above, solar generation is an intermittent source of supply, which must be supported by backup generation. In addition, MEC provides network facilities that support customers around the clock to meet their demand/load they place on the MEC system. To be equitable to all MEC consumers, those with on-site solar must pay for the backup generation and network services provided. Customers that have the financial means to invest in solar should not be subsidized by customers with limited financial resources who can only take advantage of MEC solar generation.

Agreement with Customers Having Private Solar Generation

To compute an equitable backup capacity charge, MEC considered the actual fixed costs of generation and network facilities and the capacity factor of solar. The resulting backup charge is \$0.02 per watt of installed solar capacity per month.

POLICY #2

MEC CUSTOMERS WITH INSTALLED SOLAR GENERATION THAT IS USED FOR THEIR OWN CONSUMPTION WILL BE ASSESSED A BACKUP CAPACITY CHARGE OF \$0.02 PER INSTALLED WATT OF SOLAR CAPACITY PER MONTH. THIS WILL BE BILLED SEPARATELY FROM THEIR NORMAL ELECTRIC SERVICE ON A SEMI-ANNUAL BASIS IN ADVANCE AND PAYMENT IS DUE WITHIN 45 DAYS OF THE INVOICE DATE.

If a facility wants to self-generate and not be connected to the MEC network, they are free to do so. If they subsequently decide to connect to the MEC network, they will be assessed standard connection charges along with the monthly applicable tariff and the Backup Capacity Charge.

Implementation will begin on October 1, 2025 for all customers identified as having solar facilities.

The power system needs to limit the participation in the network of unmanaged solar PV, while allowing SHS (Small Home Solar), Commercial, and Emergency Backup systems to operate.

4.1 Governing Principle/ Regulation

Privately owned and operated solar generators and/or BESS (Battery Energy Storage Systems) can be allowed to connect behind the MEC customer (customer side of meter), provided certain conditions outlined herein are met.

1.

- a. Under no circumstances a private system can be connected on the utility side of the MEC customer meter.
- b. MEC will not provide any compensation to the customer for any amount of energy inadvertently delivered to the grid by a Privately Owned system.
- c. The Privately Owned and Operated system must be connected to the customer's private internal power distribution board, and the system and board must be compliant with the required protections scheme, as verified by MEC's inspection, prior to MEC's approval of energizing the solar system.
- d. Customer must ensure complete insulation and protection of the MEC's meter from any power surges or disturbances of any kind coming from the customer's facilities.
- e. Inverters' total harmonics shall not exceed 3%.
- f. Solar system power factor (Pf) shall be 1 and customer's facilities shall not induce variations outside of 0.95 lagging or leading, regardless of load or demand.
- g. Grounding or Earthing must be of TT or IT architecture¹.
- h. All installations must be protected with a leak to earth as well as thermal breaker of adequate commercial amperage level.

¹ In TT systems, the star point is also connected to earth through a low impedance, but the exposed conductive parts of the electrical installation are earthed independently from the system earthing. In IT systems, however, all active parts are insulated from earth or connected to earth through a high impedance.

Agreement with Customers Having Private Solar Generation

- i. MEC reserves the right to disconnect and suspend the service of any customer breaching these requirements, notwithstanding other applicable penalties as determined by MEC.

4.1.1 Solar Home Systems (SHS).

- a. Solar Home Systems (SHS) are allowed to be connected on the customer side of the MEC meter subject to Governing Principles above.
- b. The solar home systems will be exempt from Backup Capacity Charge if the installed capacity does not exceed 120 W AC.
- c. The maximum capacity of an exempt solar home system must not exceed 120 W AC of total power measured at the connection point in the customer's private internal distribution board.
- d. The system must include a Battery Energy Storage System (BESS) from which all energy of the system will be dispatched, a hybrid inverter to charge/discharge the BESS, or equivalent arrangement, and the solar array.

4.1.2 Commercial and Industrial Solar Systems.

- a. Solar systems with an installed capacity above 120 W AC (SHS) are allowed to connect behind (customer side of) the MEC meter to the customer's internal power distribution infrastructure, provided the installed solar capacity, does not exceed 100% of the contracted customer load measured at the connection point, and the entire installation complies with the above Governing Principles. All such solar systems must include 2-hour BESS capacity at a minimum², from which all energy of the customer's load will be dispatched (see Figure 1).
- b. If the solar output exceeds 100% of the contracted customer load, it must exclusively serve the customer's load behind the meter, therefore the inverter must have a dynamic derating capability, which will automatically and no less than 60 times per second, adjust the output not to exceed the customer's instantaneous load subject to limit of 100% of customer's contracted load.
- c. All inverters must be equipped with "Zero-Export" functionality with programmable limits, and an "ON-OFF" actuator is not allowed to serve this function.
- d. The inverters and all electrical and electronic equipment used behind the meter must comply with all applicable IEC & IEEE standards.
- e. The proposed technical solutions must be applicable within the US or EU power management principles, consistent with MEC's network.
- f. Equipment selection is of paramount importance and only internationally recognized high quality³ equipment will be approved by MEC.
- g. Flow dynamic study on the power management system is mandatory for large scale facilities as determined by MEC.

² For example, a one-kilowatt solar PV system must include 2 kilowatt-hours BESS system.

³ Examples of manufacturers with suitable quality equipment include: SMA, Fronius, Kaco, Solar-Edge, Outback, Tesla, ABB, Enphase, Power Electronics.

Agreement with Customers Having Private Solar Generation

- h. The system is allowed to absorb energy from the MEC network to supplement the level of charge of the BESS units, while this absorption will not exceed 25% of the contracted back up capacity.
- i. MEC's final inspection and approval along with a signed Backup Capacity Charge contract are required prior to connecting any solar system or BESS behind the meter.

Figure 1. Energy Flow Schematic

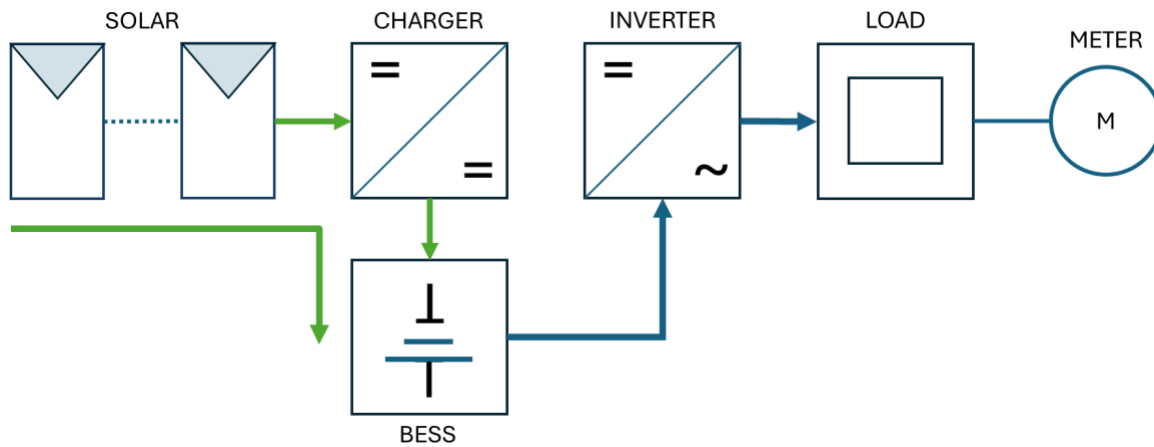

APPROVED By:

Chief Executive Officer

Date:

Agreement with Customers Having Private Solar Generation

CUSTOMER SOLAR FACILITY FORM



Marshalls Energy Company		
Customer Solar Facility Form	Number:	<i>NOTE 1</i>
Customer Name		
Customer Address		
Account Number		
Meter Number		
Installed Watts of Solar Capacity for Billing		
Description of Facilities:		
<i>NOTE 2</i>		
Customer	Name:	Date:
	Signature:	
MEC Inspector	Name:	Date:
	Signature:	
Received by Finance	Name:	Date:
	Signature:	

- Note:**
1. This is a form sequence number
 2. Describe the installation noting the number of panels by location and size (capacity), the inverter(s) and their capacity, and the manner in which the capacity is determined for billing purposes.